

Mitra

DESIGNER COLLECTION

H | S

AVAILABLE SIZES

72" L x 38" W x 24" D

WATER CAPACITY

80 Gallons

WEIGHT *(with no water)*

400 lbs. Tub Only

425 lbs. Thermal Air

BACK SLOPE

36°

STANDARD COLORS

White, Almond, Biscuit, Bone

PREMIUM COLORS

Black, Mexican Sand, Cashmere, Red, Linen, Sandbar, Sterling Silver, Ice Gray

WARRANTY

99/9 year

OPTIONS

- Thermal air
 - 1 – 20 AMP dedicated GFI
 - Blower must be remotely located
- Extra High Density Fiberglass
- Chromatherapy-LED Mini Spotlights
- Chromatherapy-LED Lighting System



- Grab Bars



- Linear Overflow
Available in multiple finishes

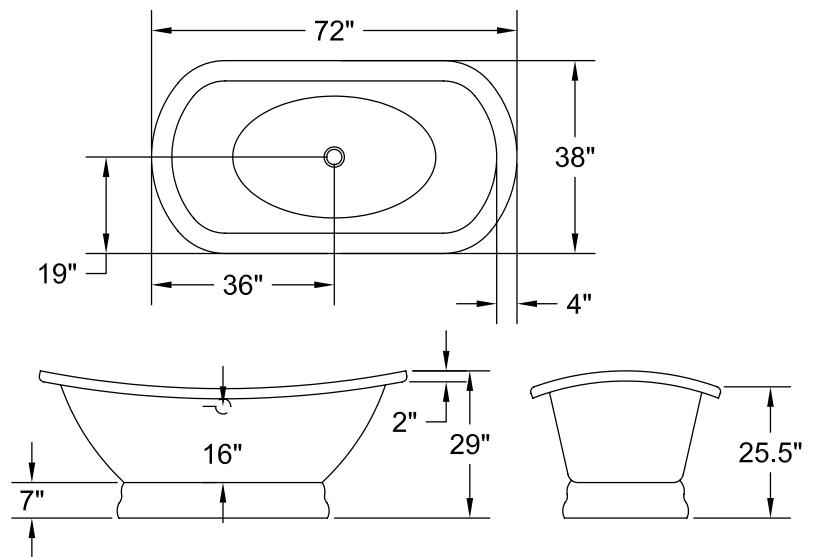

- Remote Control



- Tower



CODES AND COMPLIANCES

Massachusetts code File no: P3-0714-477

