

CHAGALL 6632

MAESTRO COLLECTION



THE MAESTRO COLLECTION

AVAILABLE SIZES

- 66.32.24

WATER CAPACITY

- 85 Gallons

WEIGHT

- 150 Pounds - Tub Only
- 180 Pounds - Thermal Air

BACK SLOPE

- 20°

MATERIAL

- Acrylic and Fiberglass

STANDARD COLORS

- White, Almond, Biscuit, Bone

PREMIUM COLORS

- Black, Mexican Sand, Cashmere, Red, Linen, Sandbar, Sterling Silver, Ice Gray

WARRANTY

- 99/9 year



OPTIONS

- Thermal Air
 - 1 -20 AMP dedicated GFI
 - Blower must be remotely located
- Extra High Density Fiberglass
- Chromotherapy-LED Mini Spotlights
- Chromotherapy- LED Lighting System
- Grab Bars
- Linear Overflow
 - Available in multiple finishes
- Remote Control
- Tower

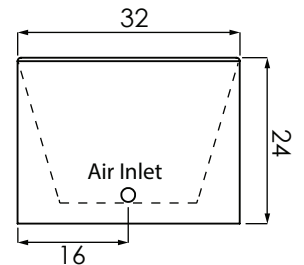
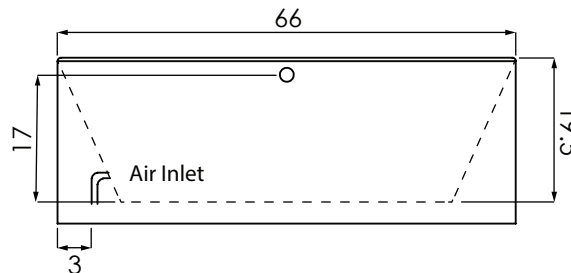
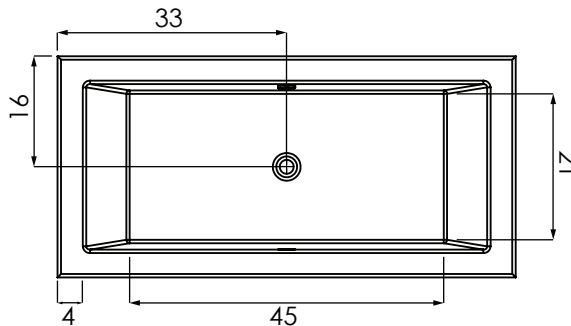

CODES AND COMPLIANCES

Massachusetts code File no: P1-0614-491



HYDRO SYSTEMS
Family Owned And Operated Since 1978

29132 Avenue Paine, Valencia, CA, 91355
661.775.0686 | hydrosystem.com

All specifications and options subject to change without notice please contact a hydro systems representative for more information.